



Model 20 HT and GT Agitators

Reliable Performance

and Value



Premium Performance

The Model 20 HT and GT units feature a gearbox designed specifically for agitator service. Available in right angle (HT) and parallel shaft (GT) configurations, this rugged performer can be tailored to meet virtually any process, from critical chemical reactor systems to storage applications.

Combining the benefits of the HT and GT time proven agitators into a modular design package, Chemineer provides solutions to optimize your mixing applica-

tions today and flexibility to handle your changing requirements in the future.

The Model 20 HT/GT is designed to meet AGMA, OSHA, ANSI, IEC, DIN, EU and ATEX standards and requirements.

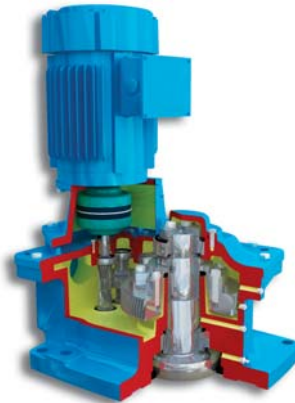

How is the Chemineer Model 20 HT/GT Gearbox Superior?

Output Shaft Requirements

Commercial gearboxes usually have smaller output shafts that are poorly suited for agitator duties, leading to higher gear deflections, more noise and lower reliability. For optimum mechanical integrity, it is beneficial to design the low speed shaft so that the shaft diameter between the bearings is large and the distance between the bearings is small. Commercial gearboxes tend to use smaller shaft diameters, resulting in the need to select larger and more expensive units to handle the bending moments associated with overhung loads.

AGMA Ratings when Applied to Agitators

AGMA established a general purpose standard intended to be applied to gearboxes used in a wide range of industrial applications. Agitators have particular duties that make reliance on AGMA service factors inappropriate. A standard commercial gearbox tends to use smaller shafts and larger bearing spans that result in higher deflection, wear and shorter lifespan. To obtain adequate drive life a high service factor must be applied.

The Chemineer Solution

The Chemineer Model 20 HT/GT gearbox is unique and superior because it is designed specifically for agitator duties. In comparison with a general purpose gear-drive of the same nominal AGMA torque rating, it has much longer bearing and gear lives, which

translate to lower maintenance costs and greater productivity. It also has an oversized output shaft, which reduces gear deflection and noise, with a true dry well seal to avoid the risk of leaking lubricant down the shaft.

Drive Features and Benefits

Internal Shafting

Features

- Oversized low speed shaft diameter and short bearing span
- Recessed low speed coupling half

Benefits

- Time proven design to handle shaft/impeller bending loads, reducing deflection and gear misalignment, thereby extending bearing and gear life
- Simplifies installation with no requirement to install the extension shaft up through the gearbox

Gearing

Features

- Double and triple reduction options
- Helical/spiral bevel (HT) and all helical (GT)
- Case carburized gearing
- Reverse rotation capability

Benefits

- Double/triple reduction decreases gear loads, lowers noise levels and allows for non-synthetic lubrication over competitive single reduction designs
- Most efficient gearing available; reduces energy costs
- Reduces wear rate for 20+ year service life
- Available option for process flexibility

Housing and Lubrication

Features

- Cast gearbox housing
- Dry well seal
- Bath lubrication
- Standard R&O oils and grease
- Extra seal over dry well

Benefits

- Modular design with right angle (HT) and parallel shaft (GT) configurations
- Reduces noise level
- Eliminates lubrication leaks which are common in commercial gearboxes with no dry well
- Ensures vital lubrication to gears and bearings at all operating speeds, eliminating internal/external lubrication pumps
- No synthetic lubrication is required, saving installation and maintenance costs
- Keeps oil out of dry well while moving gearbox

Bearing Design

Features

- Tapered roller output bearings with short bearing span, grease lubricated
- Tapered roller/cylindrical roller bearings, oil lubricated

Benefits

- High capacity to handle bending and thrust loads while providing long life
- Ensures cool operation, long life and low maintenance

Seal Features and Benefits

Features

- Drop collar shaft support during seal change
- Swing out or spacer spool seal change designs
- Variety of seal options from major mechanical seal vendors such as John Crane, Flowserve, Chesterton and AES
- Seal designs include cartridge single and double seals and split seals
- Low height pedestal (swing out) and seal bearing (spacer spool) design options
- Optional seal shut-off device
- Jacks-n-Rails assembly available for large diameter seals
- Optional lip seals and stuffing boxes

Benefits

- Shaft drops easily by loosening coupling bolts, and engages by tightening the coupling bolts
- Shaft only drops 1/2" eliminating steady bearing disengagement
- No need to pull shaft up through gearbox or in-tank shaft supports
- No labor or parts required for special shaft support system
- No lifting and removing of gearbox, saving labor and downtime
- Off the shelf items from manufacturers are non-proprietary as compared to some competitive sealing systems, improving service and lowering maintenance costs
- Reduces seal change out time and shaft wear as compared to non-cartridge (shaft mounted) designs
- Seal located close to shaft support bearings (swing out) and integral seal bearing (spacer spool) reduces shaft deflections at seal, improving life
- Eliminates operator exposure to hazardous vapors without draining the vessel
- Reduces labor time for seal change-out with no extra hoists required
- Low cost lip seals available for low pressure applications
- Self-lubricating packing offers low maintenance sealing options for pressures up to 100 psi



Swing Out Seal Change

Mounting Options

Open Tank

• Drive Mounted to Beams

Using a heavy-duty, cast housing capable of handling maximum loads, the agitator mounts readily to support beams or similar structures for common open tank applications.

• Pedestal-Mounted to Beams

The rugged, cast iron pedestal of the agitator raises the gear drive 10 inches away from the support structure to prevent exposure of the drive to the fluid and to facilitate service.

Closed Tank — Seal Options

• Lip Seal

The spring-loaded, nitrile rubber lip seal protects process fluid from contamination in lower pressure applications.

• Stuffing Box

The six-ring stuffing box utilizes standard PTFE/graphite-braided packing requiring no lubrication. Optional packing materials are available.

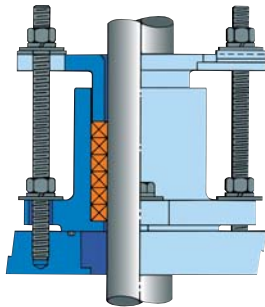

• Single Mechanical Seal

The single dry-running mechanical seal is the economical choice where a pressurized barrier between the tank contents and the outside environment is not necessary.

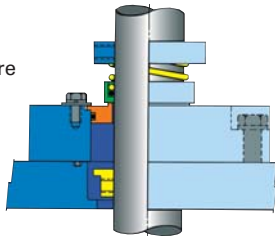

• Single Mechanical Cartridge Seal

The single mechanical seal offers dry-running capability with an easily replaceable cartridge.

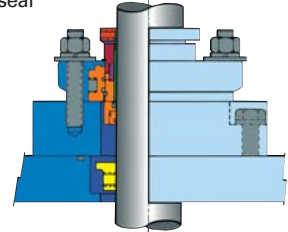

• Split Mechanical Seal

The two-piece design simplifies installation and maintenance.

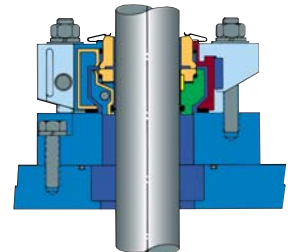

• Double Mechanical Cartridge Seal

Double mechanical cartridge seals offer excellent sealing capabilities, long life and minimum maintenance. An appropriate barrier keeps tank contents in the tank.

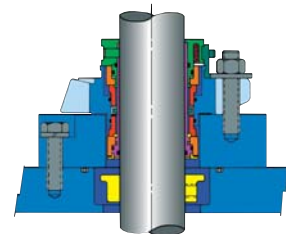

Shaft Design

Both process and mechanical considerations determine shaft design. Shafts are sized to resist torsional loads and bending moments induced by hydraulic forces acting on the impeller, as well as to avoid excessive vibration due to the coincidence of critical frequencies and operating speed.

Shafting is straightened to tight tolerances for long seal life and smooth operation – less than 0.003 inches total run out per foot of shaft length (0.25 mm per meter).

Custom couplings, impellers, shafts and steady bearings are available upon request, including sanitary designs.

Types

Shafting is supplied in a single piece design or in rigidly coupled sections for easy installation. For large diameter shafts, pipe shafting is a viable option with couplings and impeller hubs welded to the shafting. A wide range of materials and coating options are available.

Couplings

To facilitate assembly in the field, extension shafts are attached to the drive shaft with flanged rigid couplings, eliminating the need for shafts to be installed through the gearbox. Optional in-tank couplings can either be removable tapered bore or welded simplifying installation of long shafts.

Steady Bearings

Steady bearings are available to help support extremely long shafts. Tripod, bracket and pad-type steady bearings are standard design options.

Extended Keyways

Extended keyways for adjusting impeller location offer process and design flexibility.



Standard Spacer-Spool Style Pedestal and Seal Arrangement



Welded Coupling



Removable Coupling

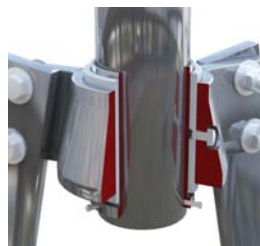

Tripod Steady Bearing



Bracket Steady Bearing

Impeller Technology

Chemineer's impeller technology is effectively applied across your spectrum of applications ensuring successful, repeatable results from lab scale to full scale operations.

Chemineer's mixing expertise includes high flow, low shear liquid-liquid agitation, solids suspension, gas

dispersion, high shear blending and viscous mixing. Whether it is R&D or production phase, we have the expertise to solve your mixing challenges.

Impeller bulletin 710 is available with additional information.



SC-3



HE-3



XE-3



BT-6 Gas Dispersion



Maxflo W



Helix



*P4 - Pitched Blade
Turbine*



*Smoothline
Maxflo W*

Dimensions

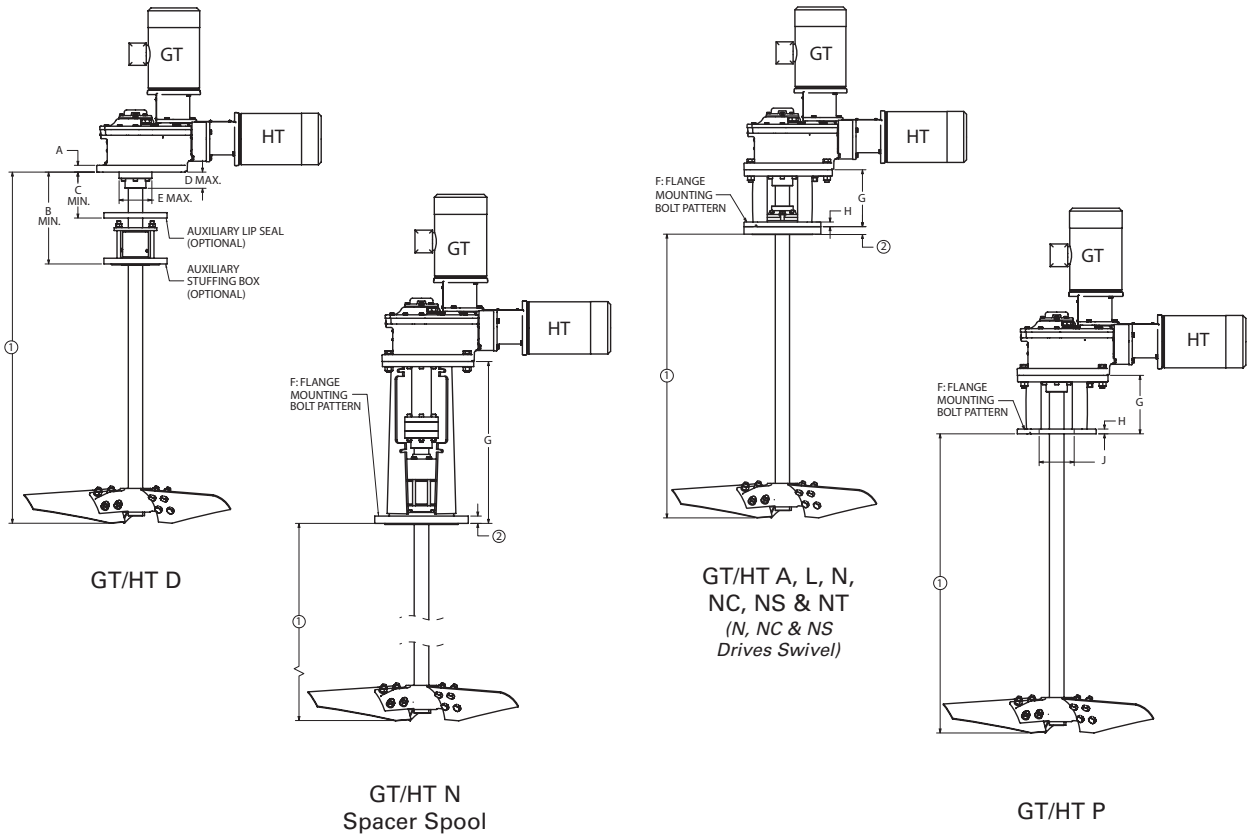

Agitator Dimensions

CASE SIZE	A	B	C	D	E	F	G		H	J
						Bolt Pattern	Spacer	Swivel		
21GT	1.18	13.94	6.94	2.94	5.71	8" - 150# ANSI (Holes Straddle C.L.)	26.19	10.00	0.75	9.50
22GT	1.38	18.00	8.00	4.00	7.48	10" - 150# ANSI (Holes On Center Line)	29.82	12.50	0.88	10.00
23GT	1.58	18.63	8.63	4.63	9.45	12" - 150# ANSI (Holes Straddle C.L.)	33.94	14.06	1.18	10.83
21HT	1.18	13.94	6.94	2.94	5.71	8" - 150# ANSI (Holes Straddle C.L.)	26.19	10.00	0.75	9.50
22HT	1.38	18.00	8.00	4.00	7.48	10" - 150# ANSI (Holes On Center Line)	29.82	12.50	0.88	10.00
23HT	1.58	18.63	8.63	4.63	9.45	12" - 150# ANSI (Holes Straddle C.L.)	33.94	14.06	1.18	10.83

1. Agitator output speed, shaft diameter and extension, impeller design and other optional features to suit application
2. Alternate flange sizes are available

Dimensions

Swivel Dimensions

CASE SIZE	K	L
21GT	11.18	17.57
22GT	17.50	22.61
23GT	21.90	28.31
21HT	9.84	17.57
22HT	12.56	22.61
23HT	16.61	28.31

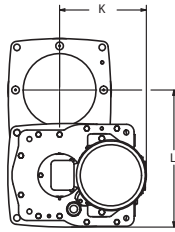

GT

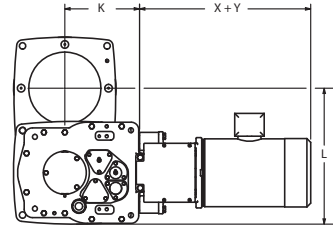

HT

Typical Drive Assembly

Swivel Dimensions

(Drive assembly pivots at top of pedestal to allow change-out of mechanical seals. See I.O.M. for special motor conduit instructions)

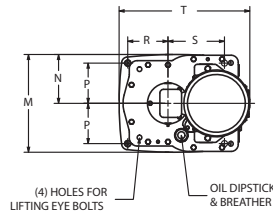

(4) HOLES FOR LIFTING EYE BOLTS
OIL DIPSTICK & BREATHER

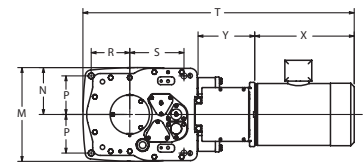

Motor Dimensions									
FRAME SIZE	W	X	Y						
			21GT	22GT	23GT	21HT	22HT	23HT	
NEMA	140	7.75	13.11	3.98	—	—	6.46	—	—
	180	9.25	16.24	5.51	6.02	—	7.99	9.41	—
	210	11.00	17.96	5.51	6.02	—	7.99	9.41	—
	250	12.75	22.25	—	6.85	7.01	—	10.24	11.43
	280	14.50	24.24	—	7.76	7.01	—	11.14	11.43
	320	16.88	27.00	—	8.23	8.27	—	11.61	12.69
	360	18.50	27.63	—	—	9.49	—	—	13.91
	400	20.88	31.75	—	—	10.83	—	—	15.25
IEC	80	6.61	10.66	3.58	—	—	6.06	—	—
	90	7.40	11.18	4.13	—	—	6.62	—	—
	100	7.72	13.15	4.92	5.35	—	7.40	8.74	—
	112	9.45	13.03	4.92	5.35	—	7.40	8.74	—
	132	10.16	16.73	5.39	6.22	6.10	7.88	9.61	10.52
	160	12.52	21.26	—	7.87	7.48	—	11.26	11.90
	180	14.37	23.31	—	7.87	7.48	—	11.26	11.90
	225	17.64	30.51	—	—	9.53	—	—	13.95
	250	20.00	35.04	—	—	9.53	—	—	13.95
280	22.17	38.39	—	—	9.53	—	—	13.95	

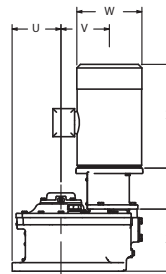

GT

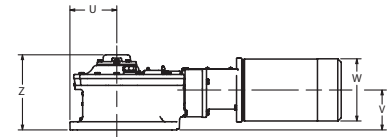

HT

Drive Assembly Dimensions

CASE SIZE	M	N	P	R	S	T	U	V	Z
21GT	12.77	6.45	5.56	5.56	7.81	17.91	6.73	6.69	8.47
22GT	16.97	8.48	7.06	7.06	10.06	26.00	8.50	9.06	10.75
23GT	21.97	10.99	9.65	7.68	2.17	31.15	9.25	11.41	14.80
21HT	12.77	6.45	5.56	5.56	7.81	38.75	6.73	5.75	10.83
22HT	16.97	8.48	7.06	7.06	10.06	59.70	8.50	7.23	12.91
23HT	21.97	10.99	9.65	7.68	2.17	73.47	9.25	9.77	16.50

Process & Mechanical Technology & Innovation

Chemineer brings proven technical expertise to each mixing solution, from basic mixer and impeller design through complex process application analysis. Combined with proprietary data evaluation methodology and extensive field experience, Chemineer provides the most accurate application evaluation possible. Let Chemineer optimize your application, saving you time and money, by applying our experience and state-of-the-art tools, such as:

- Chemineer's high-tech customer test lab—offers the most advanced testing techniques in the industry
- Computational Fluid Dynamics (CFD)—provides visual projections of mixer performance by generating a series of mathematical models of fluid flows (see Bulletin 750)
- Digital Particle Image Velocimetry (DPIV)—provides instantaneous flow visualization and quantitative measurement of the fluid velocity field (see Bulletin 755)
- Laser Doppler Anemometry (LDA)—corroborates time averaged DPIV data, especially for velocity fields in the vicinity of the impeller
- Laser Induced Fluorescence (LIF)—enables the user to gain a fundamental understanding of mixing by tracking the path and diffusion of injectants in agitated vessels and static mixers
- CEDS® (Chemineer Expert Design System)—the industry leader in agitator design and analysis software. This proprietary program suite optimizes process performance, in addition to mechanical integrity, strength and reliability
- ChemScale®—the industry standard method for effective mixer selection that helps to optimize the agitator design for your specific process needs
- Finite Element Analysis (FEA)—dynamic vibrational and stress analysis of vessel and agitator support structures ensures proper design to handle agitator loads. Product design tool for stress and deformation analysis ensures product safety and reliability
- CAD 3-D Design—state of the art product and job design software, with customer specific mixer drawings available
- A library of Chemineer technical articles—available on the web site at www.chemineer.com/techarticles.php

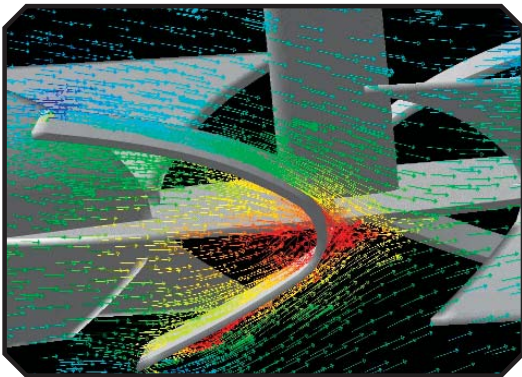

Example of CFD Modeled Flow Fields

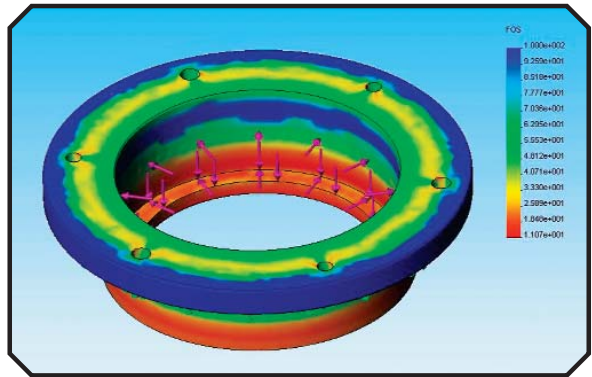

Example of FEA Analysis

Aftermarket & Technical Support

Quality Assurance

At Chemineer, quality is more than a mission, it's the foundation of our business. Design and manufacturing of parts are the building blocks of the foundation ... the toughest, most dependable components available in the industry. Utilizing Chemineer replacement parts lets you take advantage of today's technology to extend the service life of your mixing equipment.

Sales

Chemineer's extensive network of factory trained field sales representatives and in-house application engineers are on call, ready to assist you with all of your agitation needs, including installation, maintenance and modifications.

Installation

Chemineer offers expert help on installation, whether your application requires one or multiple agitators. Our sales and field service engineers can quickly and efficiently supervise the installation and start-up of your agitator.

Maintenance

Chemineer engineers can provide seminars to thoroughly review procedures recommended for installation, operation and maintenance of your agitators. We can help make your maintenance tasks easier and more efficient.

Troubleshooting

Chemineer engineers are available for troubleshooting your Model 20 HT/GT. Through years of experience and technical expertise, the engineer can pinpoint problems quickly, saving you downtime and labor.

Parts

Our large inventory supports your stock and provides quick fulfillment of maintenance and repair needs. Emergency parts are shipped from our stock within 24 hours. In addition to a wide selection of standard replacement items such as bearings, seals and motors, we stock complete drives and internal subassemblies. Our drive exchange program offers a replacement drive for rapid conversion.

Warranty

For added peace of mind the Model 20 HT/GT agitator is backed by a comprehensive two-year product warranty.





Fluid Management Group

Chemineer, Inc. is part of the family of businesses that comprise the Fluid Management Group of Robbins & Myers, Inc. The Robbins & Myers Fluid Management Group is a leading provider of innovative fluid management solutions that deliver superior performance, long service life and exceptional value. The Group brings together its global resources — engineering, manufacturing, application expertise and cutting-edge, proprietary technology — to deliver high quality, dependable products, effective system solutions and responsive support services to benefit customers worldwide.

Satisfying a broad range of application needs, the Fluid Management Group focuses its resources on the oil and gas discovery and recovery, chemical process, water and wastewater, food, biofuels, pulp and paper, pharmaceutical and numerous other industries.

The Fluid Management Group's parent company, Robbins & Myers, Inc., supplies highly-engineered, critical equipment and systems for global energy, industrial, municipal, chemical and pharmaceutical markets. Robbins & Myers provides innovative products, application engineering expertise, customer support and a competitive cost structure that create value for its customers.



Chemineer, Inc.
P.O. Box 1123
Dayton, Ohio 45401
Telephone: (937) 454-3200
Fax: (937) 454-3379
www.chemineer.com

Chemineer, Ltd.
7 Cranmer Road
West Meadows
Derby DE21 6XT
England
Telephone: 44-1332-363175
Fax: 44-1332-290323



Chemineer, Inc.
125 Flagship Drive
North Andover, MA 01845
Telephone: (978) 687-0101
Fax: (978) 687-8500
www.kenics.com
www.greercomixers.com

Chemineer International Sales Offices:

Brazil
Mexico
Singapore
China
India

Your Local Contact:

Bulletin 705

For the nearest sales office call 1-800-643-0641 or go to www.chemineer.com